

# ROTOMECH

## CYCLONE 'C28'

Rasaerba a 3 giranti ad asse verticale  
Three spindle grooming mower  
Tondeuse à 3 lames à axe vertical  
3-Messer-Rasenmäher

- ▶ Gearbox 540 rpm
- ▶ Frame
- ▶ Spindles
- ▶ Gearbox 1000 rpm
- ▶ Cat. 1N
- ▶ Driveline
- ▶ Gearbox 2000 rpm

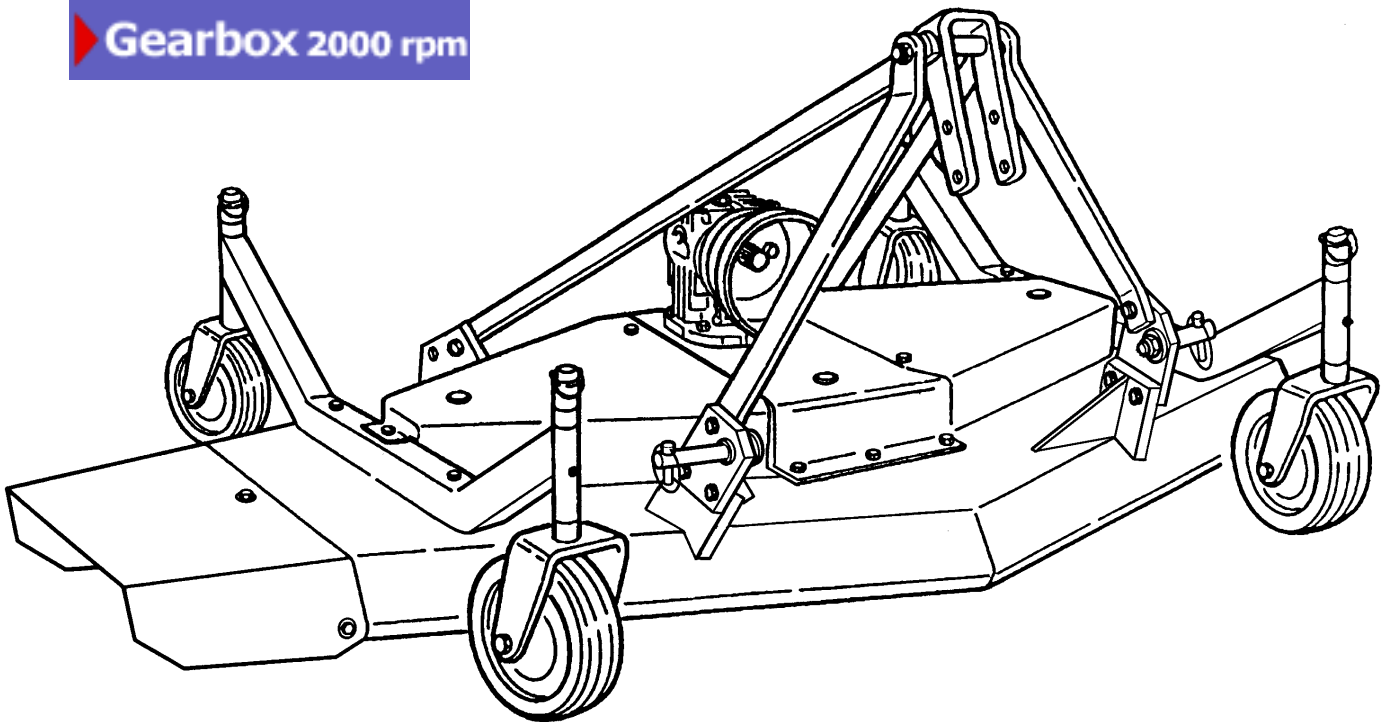

# Rotomec: Cyclone 'C28'

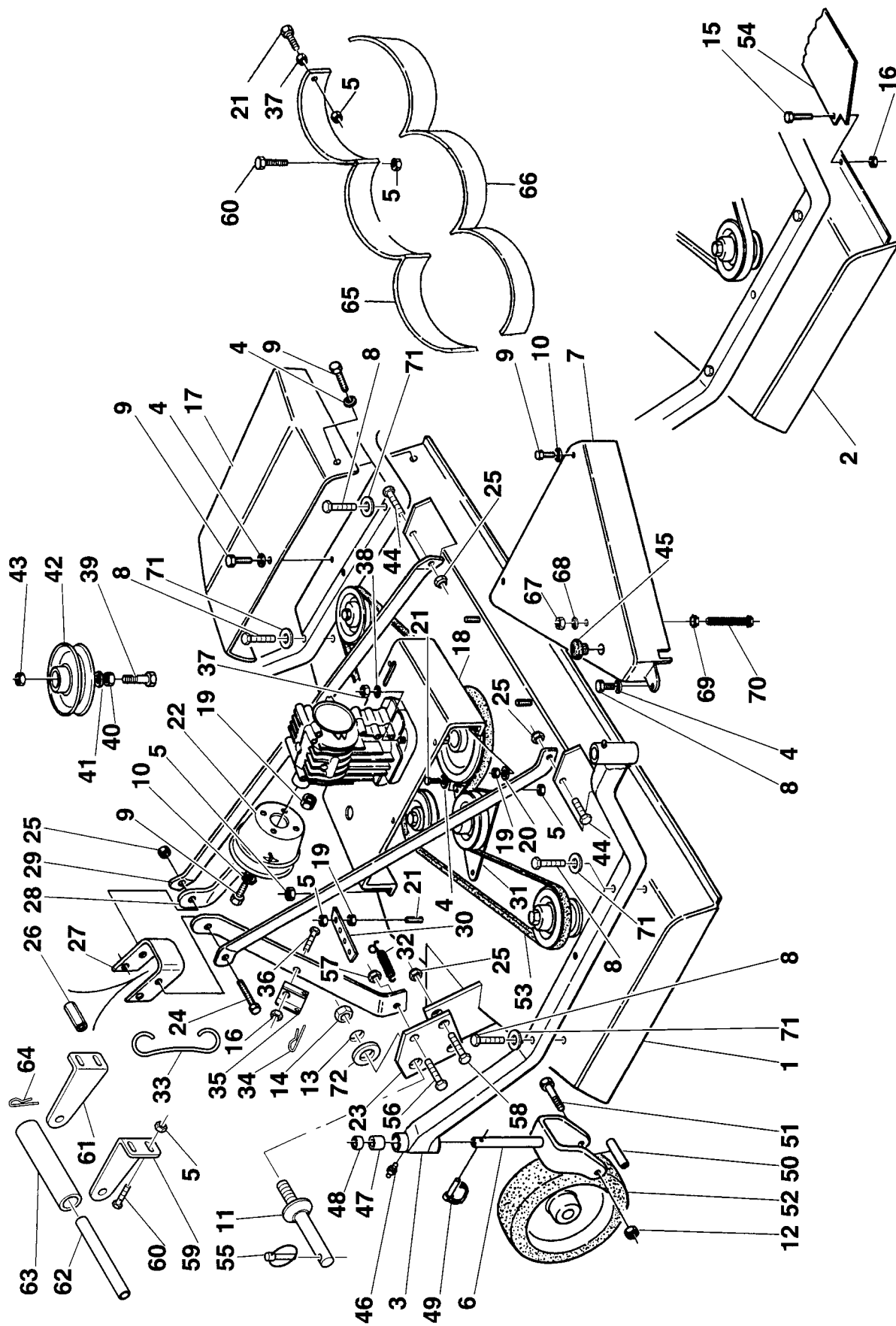

# Rotomec: Cyclone 'C28'

N.	COD.	DESCRIZIONE	DESCRIPTION	DESCRIPTION	BESCHREIBUNG	N.
1	0151501	Telaio v.120 scarico laterale	Frame v.120 side discharge	Châssis v.120 éjection latérale	Seitenauswurfrahmen v.120	1
	0251501	Telaio v.150 scarico laterale	Frame v.150 side discharge	Châssis v.150 éjection latérale	Seitenauswurfrahmen v.150	1
	0351501	Telaio v.180 scarico laterale	Frame v.180 side discharge	Châssis v.180 éjection latérale	Seitenauswurfrahmen v.180	1
2	0151501P	Telaio v.120 scarico posteriore	Frame v.120 rear discharge	Châssis v.120 éjection arrière	Heckauswurfrahmen v.120	1
	0251501P	Telaio v.150 scarico posteriore	Frame v.150 rear discharge	Châssis v.150 éjection arrière	Heckauswurfrahmen v.150	1
	0351501P	Telaio v.180 scarico posteriore	Frame v.180 rear discharge	Châssis v.180 éjection arrière	Heckauswurfrahmen v.180	1
3	0051772	Braccio ruotina v.120	Wheel arm v.120	Bras de roue v.120	Radarm v.120	2
	0051781	Braccio ruotina v.150	Wheel arm v.150	Bras de roue v.150	Radarm v.150	2
	0051783	Braccio ruotina v.180	Wheel arm v.180	Bras de roue v.180	Radarm v.180	2
4	0030157	Rondella piana D.10	Flat washer D.10	Rondelle plate D.10	Flache Scheibe D.10	10
5	0030156	Dado D.10	Nut D.10	Ecrou D.10	Mutter D.10	11
6	0008785	Forcella porta ruota	Wheel yoke	Fourche pour roue	Gabel für Rad	4
7	0108811	Protezione cinghia v.120	Belt shield v.120	Protection courroie v.120	Riemenschutz v.120	2
	0108817	Protezione cinghia v.120 da 09/00	Belt shield v.120 - 09/00	Protection courroie v.120 - 09/00	Riemenschutz v.120 - 09/00	2
	0208811	Protezione cinghia v.150	Belt shield v.150	Protection courroie v.150	Riemenschutz v.150	2
	0208817	Protezione cinghia v.150 da 09/00	Belt shield v.150 - 09/00	Protection courroie v.150 - 09/00	Riemenschutz v.150 - 09/00	2
	0308811	Protezione cinghia v.180	Belt shield v.180	Protection courroie v.180	Riemenschutz v.180	2
	0308817	Protezione cinghia v.180 da 09/00	Belt shield v.180 - 09/00	Protection courroie v.180 - 09/00	Riemenschutz v.180 - 09/00	2
8	0026185	Vite TE 10x90	Bolt TE 10x90	Vis TE 10x90	Schraube TE 10x90	6
9	0033176	Vite TE 10x25	Bolt TE 10x25	Vis TE 10x25	Schraube TE 10x25	7
10	0002034	Rondella piana D.10	Flat washer D.10	Rondelle plate D.10	Flache Scheibe D.10	4
11	0005550	Spina attacco trattore	Hitch pin	Axe attelage tracteur	Schlepperanschlufstift	2
12	0030358	Dado D.14	Nut D.14	Ecrou D.14	Mutter D.14	4
13	0005351	Rosetta elastica D.20	Spring washer D.20	Rondelle élastique D.20	Sprengring D.20	2
14	0005542	Dado D.20	Nut D.20	Ecrou D.20	Mutter D.20	2
15	0015012	Vite TE 8x20	Bolt TE 8x20	Vis TE 8x20	Schraube TE 8x20	3
16	0001806	Dado D.8	Nut D.8	Ecrou D.8	Mutter D.8	4
17	0108425	Deflettore v.120	Deflector v.120	Défecteur v.120	Leitblech v.120	1
	0208425	Deflettore v.150	Deflector v.150	Défecteur v.150	Leitblech v.150	1
	0308425	Deflettore v.180	Deflector v.180	Défecteur v.180	Leitblech v.180	1
18	0051581	Piastra centrale v.120	Central plate v.120	Plaque centrale v.120	Zentrale Platte v.120	1
	0051583	Piastra centrale v.150	Central plate v.150	Plaque centrale v.150	Zentrale Platte v.150	1
	0051585	Piastra centrale v.180	Central plate v.180	Plaque centrale v.180	Zentrale Platte v.180	1
19	0001279	Dado D.10	Nut D.10	Ecrou D.10	Mutter D.10	5
20	0001280	Rosetta elastica D.10	Spring washer D.10	Rondelle élastique D.10	Sprengring D.10	2
21	0091281	Vite TE 10x35	Bolt TE 10x35	Vis TE 10x35	Schraube TE 10x35	4
22	0008663	Protezione cardano	Shaft protection	Protection arbre	Kardangelenschutz	1
23	0051817	Piastra di giunzione	Linking plate	Plaque de jonction	Verbindungsplatte	2
24	0006891	Vite TE 16x140	Bolt TE 16x140	Vis TE 16x140	Schraube TE 16x140	1
25	0005581	Dado D.16	Nut D.16	Ecrou D.16	Mutter D.16	7
26	0006829	Distanziale	Spacer	Entretoise	Distanzstück	1



# Rotomec: Cyclone 'C28'

N.	COD.	DESCRIZIONE	DESCRIPTION	DESCRIPTION	BESCHREIBUNG	N.
27	0006828	Piastra superiore	Upper plate	Plaque supérieure	Obere Platte	1
28	0051822	Lama verticale	Top hitch support	Lame verticale	Vertikale Strebe	2
29	0051824	Lama inclinata v.120	Top hitch arm v.120	Lame inclinée v.120	Geneigte Strebe v.120	2
	0051826	Lama inclinata v.150	Top hitch arm v.150	Lame inclinée v.150	Geneigte Strebe v.150	2
	0051828	Lama inclinata v.180	Top hitch arm v.180	Lame inclinée v.180	Geneigte Strebe v.180	2
30	0008571	Piatto tirante	Hitch plate	Plaque pivot	Zugbolzenteller	1
31	0008563	Supporto tendicinghia	Belt tensioner support	Palier tendeur courroie	Riemenspannersupport	1
32	0008586	Molla	Spring	Ressort	Feder	1
33	0022433	Gancio sostegno cardano	Driveline hook	Crochet	Kardangelenstützhaken	1
34	0054422	Copiglia a molla D.2	Cotter pin D.2	Goupille ressort D.2	Federsplint D.2	1
35	0022435	Fissaggio per gancio	Hook support	Arrêt pour levier	Fixierung für Haken	1
36	0091446	Vite TE 8x25	Bolt TE 8x25	Vis TE 8x25	Schraube TE 8x25	1
37	0003038	Dado D.12	Nut D.12	Ecrou D.12	Mutter D.12	6
38	0001077	Rosetta elastica D.12	Spring washer D.12	Rondelle élastique D.12	Sprengring D.12	4
39	0008576	Vite TE 20x65	Bolt TE 20x65	Vis TE 20x65	Schraube TE 20x65	1
40	0005508	Dado D.20	Nut D.20	Ecrou D.20	Mutter D.20	1
41	0046555	Rondella piana D.20	Flat washer D.20	Rondelle plate D.20	Flache Scheibe D.20	3
42	0008561	Puleggia tendicinghia	Pulley belt tensioner	Poulie tendeur courroie	Riemenscheibenspanner	2
43	0005507	Dado D.20	Nut D.20	Ecrou D.20	Mutter D.20	2
44	0032687	Vite TE 16x40	Bolt TE 16x40	Vis TE 16x40	Schraube TE 16x40	2
45	0006647	Tappo	Cap	Bouchon d'huile	Deckel	3
46	0001065	Ingrassatore	Grease fitting	Graisneur	Schmiernippel	4
47	0006587	Distanziale 1/2"	Spacer 1/2"	Entretoise 1/2"	Distanzstück 1/2"	8
48	0006586	Distanziale 1"	Spacer 1"	Entretoise 1"	Distanzstück 1"	8
49	0006610	Copiglia D.6x46	Cotter pin D.6x46	Goupille D.6x46	Splint D.6x46	4
	0008783	Copiglia-07.1999	Cotter pin-07.1999	Goupille-07.1999	Splint-07.1999	4
50	0008528	Distanziale	Spacer	Entretoise	Distanzstück	4
51	0006615	Vite TE 14x140	Bolt TE 14x140	Vis TE 14x140	Schraube TE 14x140	4
52	0008526	Ruota gommata piena	Hard tire	Roue caoutchoutée	Gummirad	4
	0008797	Ruota pneumatica	Air tire	Roue pneumatique	Luftreifen	4
53	0008630	Cinghia BX 98	Belt BX 98	Courroie BX 98	Keilriemen BX 98	1
	0008670	Cinghia BX 112 1/2	Belt BX 112 1/2	Courroie BX 112 1/2	Keilriemen BX 112 1/2	1
	0008950	Cinghia BX 140	Belt BX 140	Courroie BX 140	Keilriemen BX 140	1
	0008718	Cinghia BX 96 2000 rpm	Belt BX 96 2000 rpm	Courroie BX 96 2000 rpm	Keilriemen BX 96 2000 rpm	
	0008719	Cinghia BX 110 2000 rpm	Belt BX 110 2000 rpm	Courroie BX 110 2000 rpm	Keilriemen BX 110 2000 rpm	
	0008720	Cinghia BX 138 2000 rpm	Belt BX 138 2000 rpm	Courroie BX 138 2000 rpm	Keilriemen BX 138 2000 rpm	
54	0108420	Prolunga posteriore v.120	Rear extension v.120	Prolonge arrière v.120	Hintere Verlängerung v.120	1
	0208420	Prolunga posteriore v.150	Rear extension v.150	Prolonge arrière v.150	Hintere Verlängerung v.150	1
	0308420	Prolunga posteriore v.180	Rear extension v.180	Prolonge arrière v.180	Hintere Verlängerung v.180	1

# Rotomec: Cyclone 'C28'

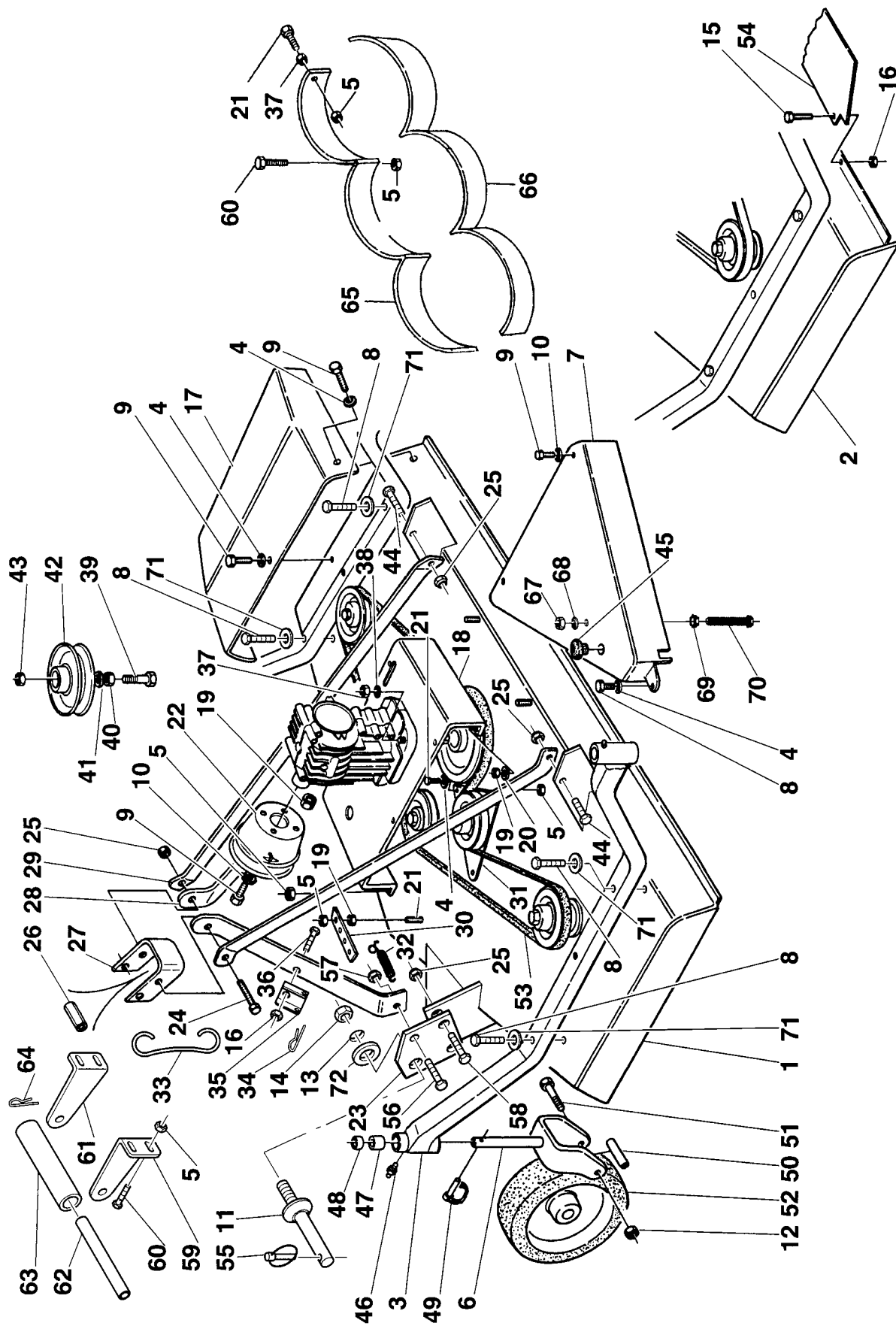

# Rotomec: Cyclone 'C28'

<b>N.</b>	<b>COD.</b>	<b>DESCRIZIONE</b>	<b>DESCRIPTION</b>	<b>DESCRIPTION</b>	<b>BESCHREIBUNG</b>	<b>N.</b>
55	0018266	Copiglia a spina	Lynch pin	Goupille de sécurité	Klappsplint	2
56	0009538	Vite TE 20x45	Bolt TE 20x45	Vis TE 20x45	Schraube TE 20x45	2
57	0005507	Dado D.20	Nut D.20	Ecrou D.20	Mutter D.20	2
58	0006578	Vite TE 16x45	Bolt TE 16x45	Vis TE 16x45	Schraube TE 16x45	4
59	0208924	Supporto rullo sinistro	Left roller support	Palier rouleau gauche	Linke Walzenstütze	1
60	0006349	Vite TE 10x20	Bolt TE 10x20	Vis TE 10x20	Schraube TE 10x20	8
61	0008923	Supporto rullo destro	Right roller support	Palier rouleau droit	Rechte Walzenstütze	1
62	0008929	Perno rullo	Roller pin	Tourillon rouleau	Rollenzapfen	1
63	0067358	Rullo anteriore	Front roller	Rouleau antérieur	Vordere Walze	1
64	0112087	Copiglia D.4x50	Cotter pin D.4x50	Goupille D.4x50	Splint D.4x50	2
65	0008755	Convogliatore v.120	Baffling v.120	Convoyeur v.120	Förderer v.120	1
	0115824	Convogliatore v.150	Baffling v.150	Convoyeur v.150	Förderer v.150	1
	0008759	Convogliatore v.180	Baffling v.180	Convoyeur v.180	Förderer v.180	1
66	0008756	Convogliatore v.120	Baffling v.120	Convoyeur v.120	Förderer v.120	1
	0115825	Convogliatore v.150	Baffling v.150	Convoyeur v.150	Förderer v.150	1
	0008760	Convogliatore v.180	Baffling v.180	Convoyeur v.180	Förderer v.180	1
67	0015237	Dado D.10	Nut D.10	Ecrou D.10	Mutter D.10	2
68	0030157	Rondella piana D.10	Flat washer D.10	Rondelle plate D.10	Flache Scheibe D.10	2
69	0014106	Dado D.10	Nut D.10	Ecrou D.10	Mutter D.10	2
70	0008818	Vite TE 10x110	Bolt TE 10x110	Vis TE 10x110	Schraube TE 10x110	2
71	0051776	Rondella piana D.10	Flat washer D.10	Rondelle plate D.10	Flache Scheibe D.10	6
72	0051849	Disco di appoggio	Spacing disk	Disque épaisseur	Unterlegsscheibe	2

# Rotomec: Cyclone 'C28', 540 rpm

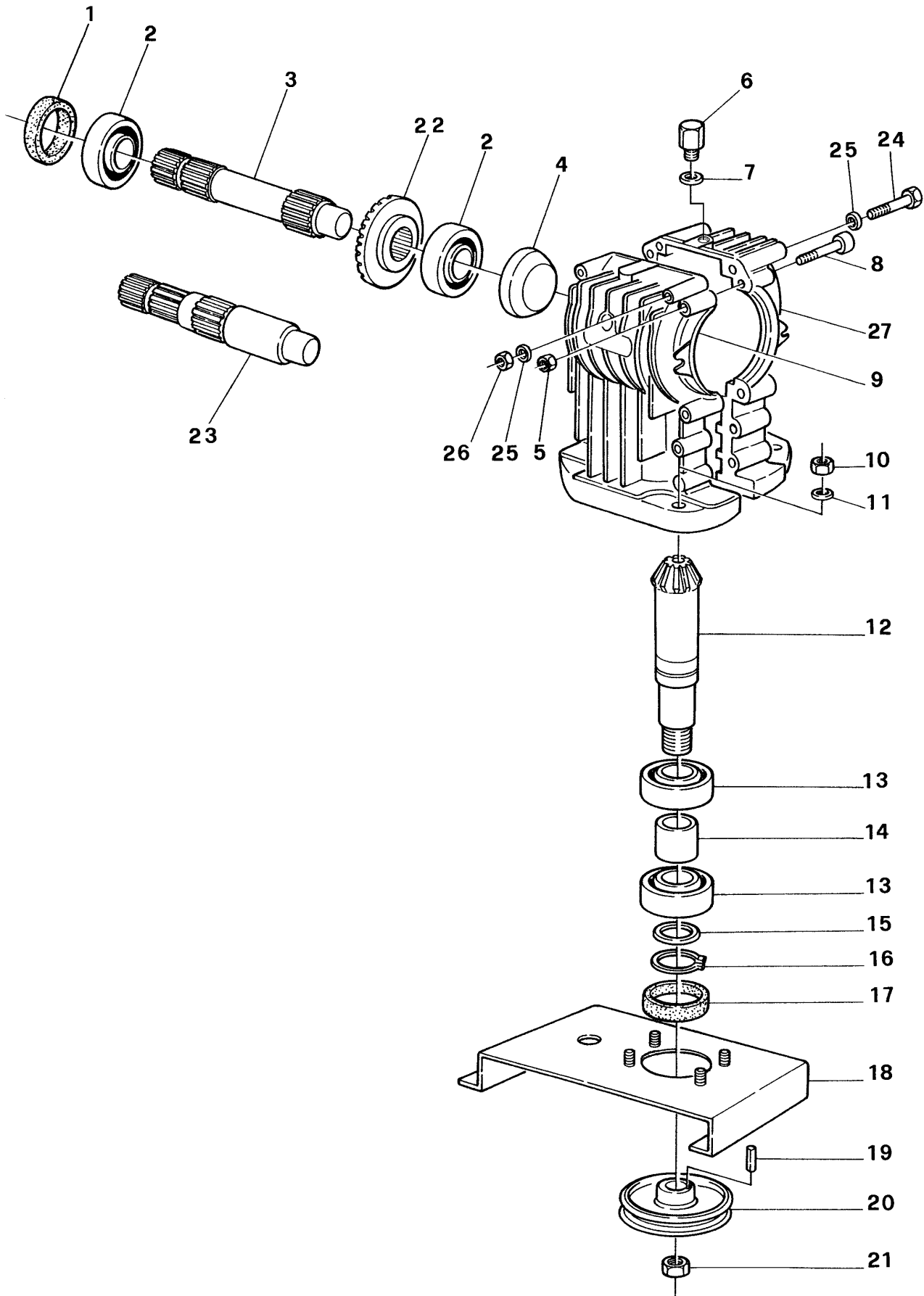



# Rotomec: Cyclone 'C28', 540 rpm

N.	COD.	DESCRIZIONE	DESCRIPTION	DESCRIPTION	BESCHREIBUNG	N.
1	0010192	Paraolio 40.68.10	Oil seal 40.68.10	Pare-huile 40.68.10	Simmering 40.68.10	1
2	0012149	Cuscinetto 6208	Bearing 6208	Roulement 6208	Lager 6208	2
3	0008892	Albero P.D.F.	Input shaft	Arbre P.D.F.	Zapfwelle	1
4	0008609	Tappo	Cap	Bouchon d'huile	Deckel	1
5	0001806	Dado D.8	Nut D.8	Ecrou D.8	Mutter D.8	8
6	0008598	Sfiatatoio	Breather cap	Bouchon d'huile	Gehäuseentlüfter	1
	0010177	Sfiatatoio-da 03/03	Breather cap-03/03	Bouchon d'huile-03/03	Gehäuseentlüfter-03/03	1
7	0008601	Guarnizione	Gasket	Joint d'étanchéité	Dichtung	1
8	0010171	Vite TCEI 8x50	Bolt TCEI 8x50	Vis TCEI 8x50	Schraube TCEI 8x50	8
9	3300101	Semiscatola senza foro	Gearbox housing without hole	Demi-boîtier sans trou	Gehäusehälfte ohne Bohrung	2
	0051896	Semiscatola senza foro-da 03/03	Gearbox housing without hole-03/03	Demi-boîtier sans trou-03/03	Gehäusehälfte ohne Bohrung-03/03	1
10	0003038	Dado D.12	Nut D.12	Ecrou D.12	Mutter D.12	4
11	0001077	Rosetta elastica D.12	Spring washer D.12	Rondelle élastique D.12	Sprengring D.12	4
12	0050192	Pignone conico	Pinion gear	Pignon conique	Kegelrad	1
13	0025332	Cuscinetto 6207	Bearing 6207	Roulement 6207	Lager 6207	2
14	0010196	Distanziale	Spacer	Entretoise	Distanzstück	1
15	0034196	Anello di spessoramento	Spacer washer	Anneau d'épaisseur	Distanzring	1
16	0042122	Seeger esterno D.35	Outer snap ring D.35	Circlip externe D.35	Außenseegerring D.35	1
17	0002295	Paraolio 35.62.10	Oil seal 35.62.10	Pare-huile 35.62.10	Simmering 35.62.10	1
18	0051581	Piastra centrale v.120	Central plate v.120	Plaque centrale v.120	Zentrale Platte v.120	1
	0051583	Piastra centrale v.150	Central plate v.150	Plaque centrale v.150	Zentrale Platte v.150	1
	0051585	Piastra centrale v.180	Central plate v.180	Plaque centrale v.180	Zentrale Platte v.180	1
19	0006688	Linguetta 8x7x35	Key 8x7x35	Clavette 8x7x35	Schlüssel 8x7x35	1
20	0008623	Puleggia SPB 250x1	Pulley SPB 250x1	Poulie 250x1	Scheibe 250x1	1
21	0006698	Dado D.25	Nut D.25	Ecrou D.25	Mutter D.25	1
22	0008893	Corona conica	Ring gear	Couronne conique	Tellerrad	1
23	0051187	Albero P.D.F. antiorario	Input shaft w/ccw rotation	Arbre P.D.F. rot. anti-horaire	Zapfwelle gegen den Uhrzeigersinn	1
24	0015263	Vite TE 10x120	Bolt TE 10x120	Vis TE 10x120	Schraube TE 10x120	2
25	0002034	Rondella piana D.10	Flat washer D.10	Rondelle plate D.10	Flache Scheibe D.10	4
26	0030156	Dado D.10	Nut D.10	Ecrou D.10	Mutter D.10	2
27	0051897	Semiscatola con foro-da 03/03	Gearbox housing with hole-03/03	Demi-boîtier avec trou-03/03	Gehäusehälfte mit Bohrung-03/03	1
	0500620	Gruppo scatola rot. oraria	Gearbox w/cw rotation	Boîtier rotation horaire	Gehäusegruppe Rotation im Uhrzeigersinn	
	0500621	Gruppo scatola rot. antioraria	Gearbox w/ccw rotation	Boîtier rotation anti-horaire	Gehäusegruppe Rotation gegen den Uhrzeigersinn	
	0500654	Gruppo scatola rot. oraria-da 03/03	Gearbox w/cw rotation-03/03	Boîtier rotation horaire-03/03	Gehäusegruppe Rotation im Uhrzeigersinn-03/03	
	0500655	Gruppo scatola rot. antioraria-da 03/03	Gearbox w/ccw rotation-03/03	Boîtier rotation anti-horaire-03/03	Gehäusegruppe Rotation gegen den Uhrzeigersinn-03/03	

# Rotomec: Cyclone 'C28', 1000 rpm

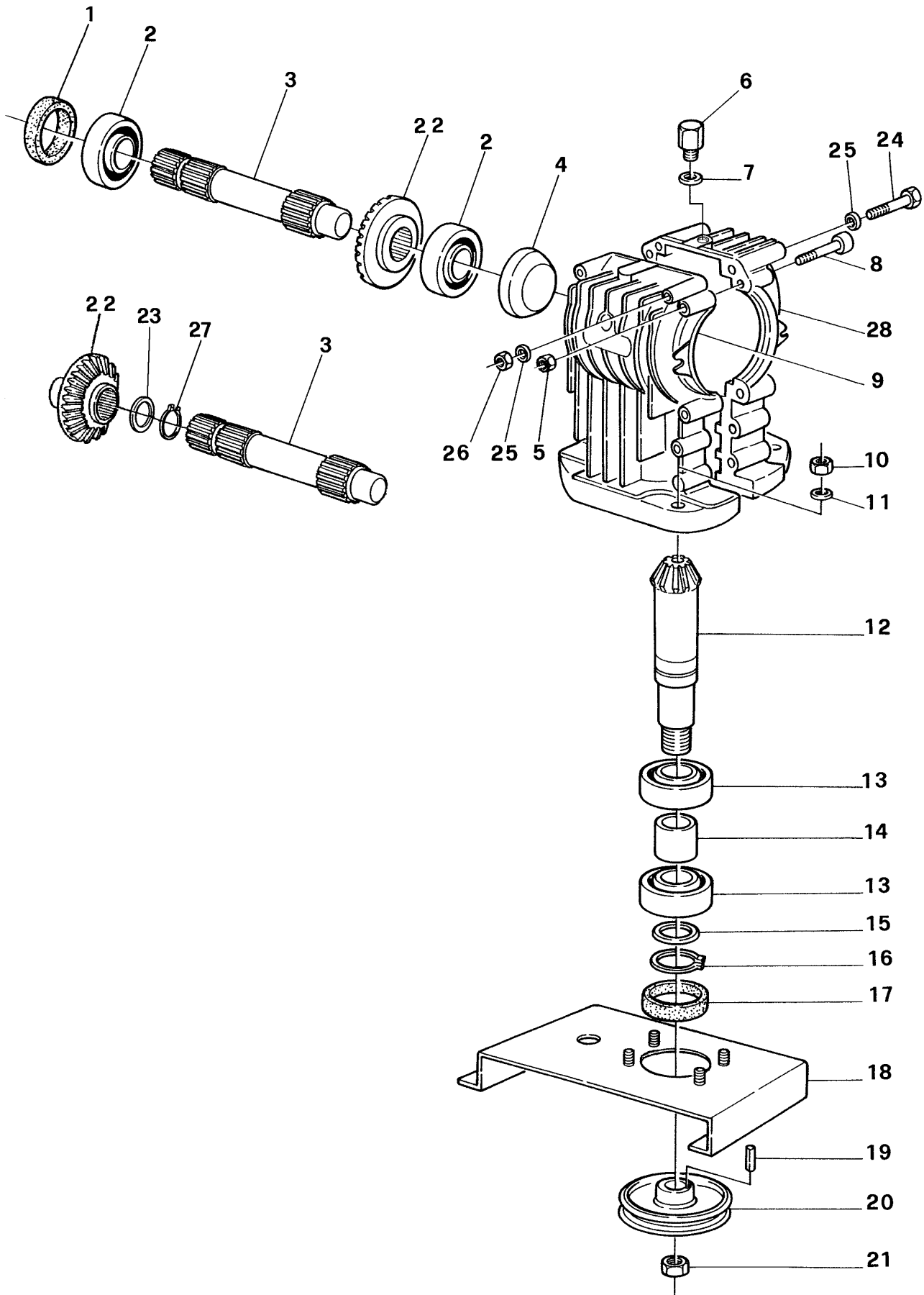

# Rotomec: Cyclone 'C28', 1000 rpm

<b>N.</b>	<b>COD.</b>	<b>DESCRIZIONE</b>	<b>DESCRIPTION</b>	<b>DESCRIPTION</b>	<b>BESCHREIBUNG</b>	<b>N.</b>
1	0010192	Paraolio 40.68.10	Oil seal 40.68.10	Pare-huile 40.68.10	Simmering 40.68.10	1
2	0012149	Cuscinetto 6208	Bearing 6208	Roulement 6208	Lager 6208	2
3	0008962	Albero P.D.F.	Input shaft	Arbre P.D.F.	Zapfwelle	1
4	0008609	Coperchiella	Cover	Couvercle	Deckel	1
5	0001806	Dado D.8	Nut D.8	Ecrou D.8	Mutter D.8	8
6	0008598	Sfiatatoio	Breather cap	Bouchon d'huile	Gehäuseentlüfter	1
	0010177	Sfiatatoio-da 03/03	Breather cap-03/03	Bouchon d'huile-03/03	Gehäuseentlüfter-03/03	1
7	0008601	Guarnizione	Gasket	Joint d'étanchéité	Dichtung	1
8	0010171	Vite TCEI 8x50	Bolt TCEI 8x50	Vis TCEI 8x50	Schraube TCEI 8x50	8
9	3300101	Semiscatola senza foro	Gearbox housing without hole	Demi-boîtier sans trou	Gehäusehälfte ohne Bohrung	2
	0051896	Semiscatola senza foro-da 03/03	Gearbox housing without hole-03/03	Demi-boîtier sans trou-03/03	Gehäusehälfte ohne Bohrung-03/03	1
10	0003038	Dado D.12	Nut D.12	Ecrou D.12	Mutter D.12	4
11	0001077	Rosetta elastica D.12	Spring washer D.12	Rondelle élastique D.12	Sprengring D.12	4
12	0008639	Pignone conico	Pinion gear	Pignon conique	Kegelrad	1
13	0025332	Cuscinetto 6207	Bearing 6207	Roulement 6207	Lager 6207	2
14	0010196	Distanziale	Spacer	Entretoise	Distanzstück	1
15	0034196	Anello di spessoramento	Spacer washer	Anneau d'épaisseur	Distanzring	1
16	0042122	Seeger esterno D.35	Outer snap ring D.35	Circlip externe D.35	Außenseegerring D.35	1
17	0002295	Paraolio 35.62.10	Oil seal 35.62.10	Pare-huile 35.62.10	Simmering 35.62.10	1
18	0051581	Piastra centrale v.120	Central plate v.120	Plaque centrale v.120	Zentrale Platte v.120	1
	0051583	Piastra centrale v.150	Central plate v.150	Plaque centrale v.150	Zentrale Platte v.150	1
	0051585	Piastra centrale v.180	Central plate v.180	Plaque centrale v.180	Zentrale Platte v.180	1
19	0006688	Linguetta 7x8x35	Key 7x8x35	Clavette 7x8x35	Schlüssel 7x8x35	1
20	0008623	Puleggia SPB 250x1	Pulley SPB 250x1	Poulie SPB 250x1	Scheibe SPB 250x1	1
21	0006698	Dado D.25	Nut D.25	Ecrou D.25	Mutter D.25	1
22	0008963	Corona conica	Ring gear	Couronne conique	Tellerrad	1
23	0053240	Anello di spessoramento	Spacer washer	Anneau d'épaisseur	Distanzring	1
24	0015263	Vite TE 10x120	Bolt TE 10x120	Vis TE 10x120	Schraube TE 10x120	2
25	0002034	Rondella piana D.10	Flat washer D.10	Rondelle plate D.10	Flache Scheibe D.10	4
26	0030156	Dado D.10	Nut D.10	Ecrou D.10	Mutter D.10	2
27	0012028	Seeger esterno D.45	Outer snap ring D.45	Circlip externe D.45	Außenseegerring D.45	1
28	0051897	Semiscatola con foro-da 03/03	Gearbox housing with hole-03/03	Demi-boîtier avec trou-03/03	Gehäusehälfte mit Bohrung-03/03	1
	0500629	Gruppo scatola rot. oraria	Gearbox w/cw rotation	Boîtier rotation horaire	Gehäusegruppe Rotation im Uhrzeigersinn	
	0500630	Gruppo scatola rot. antioraria	Gearbox w/ccw rotation	Boîtier rotation anti-horaire	Gehäusegruppe Rotation gegen den Uhrzeigersinn	
	0500656	Gruppo scatola rot. oraria-da 03/03	Gearbox w/cw rotation-03/03	Boîtier rotation horaire-03/03	Gehäusegruppe Rotation im Uhrzeigersinn-03/03	
	0500657	Gruppo scatola rot. antioraria-da 03/03	Gearbox w/ccw rotation-03/03	Boîtier rotation anti-horaire-03/03	Gehäusegruppe Rotation gegen den Uhrzeigersinn-03/03	

# Rotomec: Cyclone 'C28', 2000 rpm

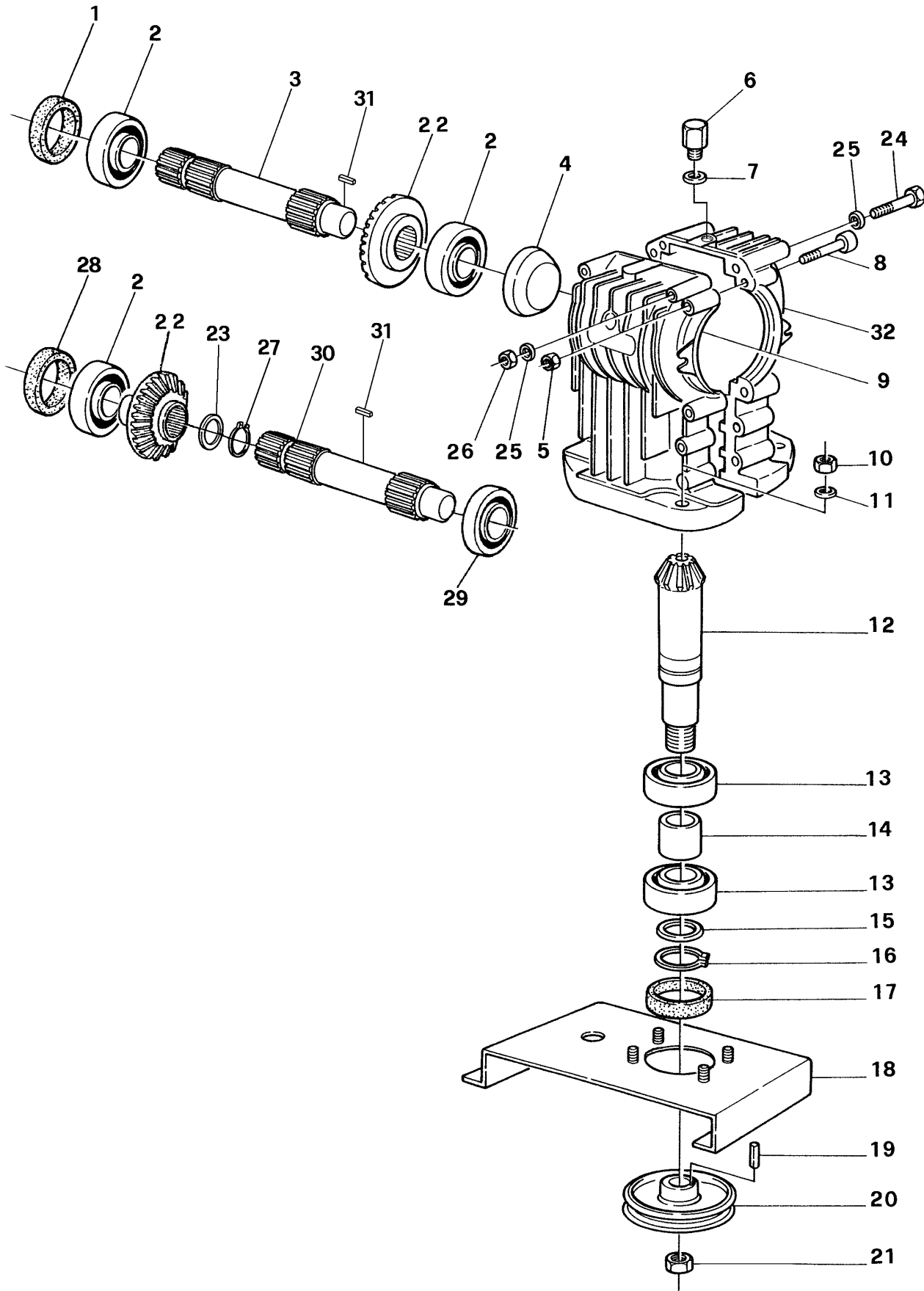

# Rotomec: Cyclone 'C28', 2000 rpm

N.	COD.	DESCRIZIONE	DESCRIPTION	DESCRIPTION	BESCHREIBUNG	N.
1	0010192	Paraolio 40.68.10	Oil seal 40.68.10	Pare-huile 40.68.10	Simmering 40.68.10	1
2	0012149	Cuscinetto 6208	Bearing 6208	Roulement 6208	Lager 6208	2
3	0008983	Albero P.D.F.	Input shaft	Arbre P.D.F.	Zapfwelle	1
4	0008609	Coperchiella	Cover	Couvercle	Deckel	1
5	0001806	Dado D.8	Nut D.8	Ecrou D.8	Mutter D.8	8
6	0008598	Sfiatatoio	Breather cap	Bouchon d'huile	Gehäuseentlüfter	1
	0010177	Sfiatatoio-da 03/03	Breather cap-03/03	Bouchon d'huile-03/03	Gehäuseentlüfter-03/03	1
7	0008601	Guarnizione	Gasket	Joint d'étanchéité	Dichtung	1
8	0010171	Vite TCEI 8x50	Bolt TCEI 8x50	Vis TCEI 8x50	Schraube TCEI 8x50	8
9	3300101	Semiscatola senza foro	Gearbox housing without hole	Demi-boîtier sans trou	Gehäusehälfte ohne Bohrung	2
	0051896	Semiscatola senza foro-da 03/03	Gearbox housing without hole-03/03	Demi-boîtier sans trou-03/03	Gehäusehälfte ohne Bohrung-03/03	1
10	0003038	Dado D.12	Nut D.12	Ecrou D.12	Mutter D.12	4
11	0001077	Rosetta elastica D.12	Spring washer D.12	Rondelle élastique D.12	Sprengring D.12	4
12	0008985	Pignone conico	Pinion gear	Pignon conique	Kegelrad	1
13	0025332	Cuscinetto 6207	Bearing 6207	Roulement 6207	Lager 6207	2
14	0010196	Distanziale	Spacer	Entretoise	Distanzstück	1
15	0034196	Anello di spessoramento	Spacer washer	Anneau d'épaisseur	Distanzring	1
16	0042122	Seeger esterno D.35	Outer snap ring D.35	Circlip externe D.35	Außenseegerring D.35	1
17	0002295	Paraolio 35.62.10	Oil seal 35.62.10	Pare-huile 35.62.10	Simmering 35.62.10.	1
18	0051581	Piastra centrale v.120	Central plate v.120	Plaque centrale v.120	Zentrale Platte v.120	1
	0051583	Piastra centrale v.150	Central plate v.150	Plaque centrale v.150	Zentrale Platte v.150	1
	0051585	Piastra centrale v.180	Central plate v.180	Plaque centrale v.180	Zentrale Platte v.180	1
19	0006688	Linguetta 7x8x35	Key 7x8x35	Clavette 7x8x35	Schlüssel 7x8x35	1
20	0008990	Puleggia SPB 180x1	Pulley SPB 180x1	Poulie SPB 180x1	Scheibe SPB 180x11	1
21	0006698	Dado D.25	Nut D.25	Ecrou D.25	Mutter D.25	1
22	0008984	Corona conica	Ring gear	Couronne conique	Tellerrad	1
23	0006606	Anello di spessoramento	Spacer washer	Anneau d'épaisseur	Distanzring	1
24	0015263	Vite TE 10x120	Bolt TE 10x120	Vis TE 10x120	Schraube TE 10x120	2
25	0002034	Rondella piana D.10	Flat washer D. 10	Rondelle plate D.10	Flache Scheibe D.10	4
26	0030156	Dado D.10	Nut D.10	Ecrou D.10	Mutter D.10	2
27	0008989	Seeger esterno D.28	Outer snap ring D.28	Circlip externe D.28	Außenseegerring D.28	1
28	0008987	Paraolio 35.68.10	Oil seal 35.68.10	Pare-huile 35.68.10	Simmering 35.68.10	1
29	0008988	Cuscinetto 6405	Bearing 6405	Roulement 6405	Lager 6405	1
30	0008986	Albero P.D.F. antiorario	Input shaft w/ccw rotation	Arbre P.D.F. rot. anti-horaire	Zapfwelle gegen den Uhrzeigersinn	1
31	0006639	Linguetta 8x7x25	Key 8x7x25	Clavette 8x7x25	Schlüssel 8x7x25	1
32	0051897	Semiscatola con foro-da 03/03	Gearbox housing with hole-03/03	Demi-boîtier avec trou-03/03	Gehäusehälfte mit Bohrung-03/03	1
	0500631	Gruppo scatola rot. oraria	Gearbox w/cw rotation	Boîtier rotation horaire	Gehäusegruppe Rotation im Uhrzeigersinn	
	0500632	Gruppo scatola rot. antioraria	Gearbox w/ccw rotation	Boîtier rotation anti-horaire	Gehäusegruppe Rotation gegen den Uhrzeigersinn	
	0500658	Gruppo scatola rot. oraria-da 03/03	Gearbox w/cw rotation-03/03	Boîtier rotation horaire-03/03	Gehäusegruppe Rotation im Uhrzeigersinn-03/03	
	0500659	Gruppo scatola rot. antioraria-da 03/03	Gearbox w/ccw rotation-03/03	Boîtier rotation anti-horaire-03/03	Gehäusegruppe Rotation gegen den Uhrzeigersinn-03/03	

# Rotomec: Cyclone 'C28'

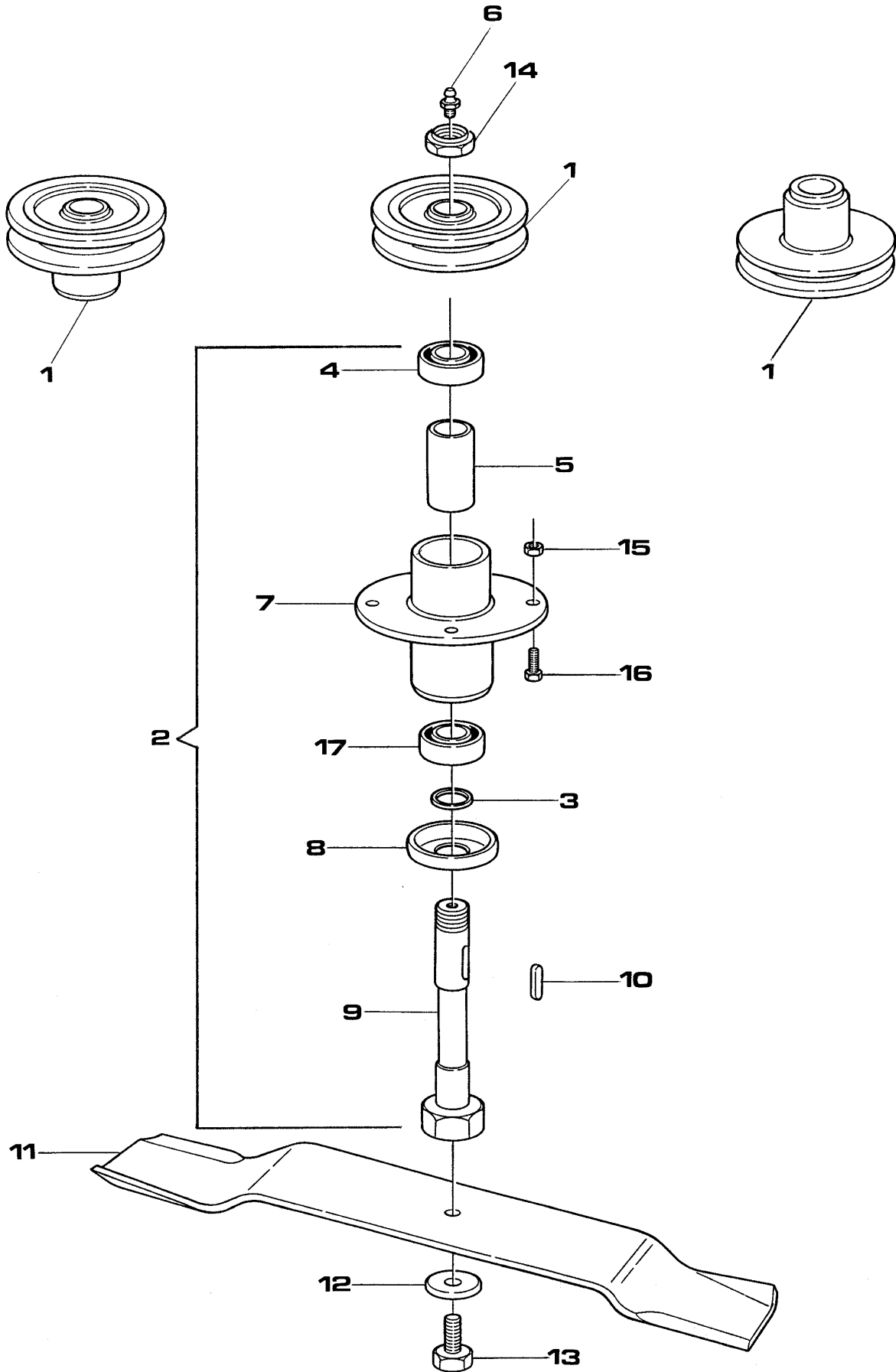

# Rotomec: Cyclone 'C28'

<b>N.</b>	<b>COD.</b>	<b>DESCRIZIONE</b>	<b>DESCRIPTION</b>	<b>DESCRIPTION</b>	<b>BESCHREIBUNG</b>	<b>N.</b>
1	0008531	Puleggia SPB 120x1 v.120	Pulley SPB 120x1 v.120	Poulie SPB 120x1 v.120	Scheibe SPB 120x1 v.120	3
	0008666	Puleggia SPB 130x1 v.150	Pulley SPB 130x1 v.150	Poulie SPB 130x1 v.150	Scheibe SPB 130x1 v.150	3
	0008881	Puleggia SPB 160x1 v.180	Pulley SPB 160x1 v.180	Poulie SPB 160x1 v.180	Scheibe SPB 160x1 v.180	3
2	0008533	Gruppo rotore	Spindle assembly	Groupe de rotor	Rotorgruppe	
3	0006606	Anello di spessoramento	Spacer washer	Anneau d'épaisseur	Distanzring	3
4	0006634	Cuscinetto 6205-Z	Bearing 6205-Z	Roulement 6205-Z	Lager 6205-Z	3
5	0008536	Distanziale	Spacer	Entretoise	Distanzstück	3
6	0029036	Ingrassatore	Grease fitting	Graisseur	Schmiernippel	3
7	0008538	Supporto rotore	Spindle	Palier rotor	Rotorsupport	3
8	0006636	Coperchiella	Cover	Couvercle	Deckel	3
9	0008557	Albero porta coltello	Spindle shaft	Arbre porte couteau	Messerwelle	3
10	0006639	Linguetta 8x7x25	Key 8x7x25	Clavette 8x7x25	Schlüssel 8x7x25	3
11	0006795	Coltello standard v.120	Standard blade v.120	Couteau standard v.120	Standard Messer v.120	3
	0006641	Coltello standard v.150	Standard blade v.150	Couteau standard v.150	Standard Messer v.150	3
	0006845	Coltello standard v.180	Standard blade v.180	Couteau standard v.180	Standard Messer v.180	3
	0006795M	Coltello sminuzzatore v.120	Mulching blade v.120	Couteau hacheur v.120	Hackmesser v.120	3
	0006641M	Coltello sminuzzatore v.150	Mulching blade v.150	Couteau hacheur v.150	Hackmesser v.150	3
	0006845M	Coltello sminuzzatore v.180	Mulching blade v.180	Couteau hacheur v.180	Hackmesser v.180	3
	0006795B	Coltello espulsore v.120	Highlift blade v.120	Couteau éjecteur v.120	Auswurfmesser v.120	3
	0006641B	Coltello espulsore v.150	Highlift blade v.150	Couteau éjecteur v.150	Auswurfmesser v.150	3
	0006845B	Coltello espulsore v.180	Highlift blade v.180	Couteau éjecteur v.180	Auswurfmesser v.180	3
	0006795F	Coltello piatto v.120	Flat blade v.120	Couteau flat v.120	Flachmesser v.120	3
	0006641F	Coltello piatto v.150	Flat blade v.150	Couteau flat v.150	Flachmesser v.150	3
	0006845F	Coltello piatto v.180	Flat blade v.180	Couteau flat v.180	Flachmesser v.180	3
12	0008560	Molla a tazza	Disc spring	Ressort à disque	Tellerfeder	3
13	0008559	Vite fissa coltello	Blade bolt	Vis de fixation couteau	Schraube	3
14	0006698	Dado D.25	Nut D.25	Ecrou D.25	Mutter D.25	3
15	0030156	Dado D.10	Nut D.10	Ecrou D.10	Mutter D.10	12
16	0001278	Vite TE 10x30	Bolt TE 10x30	Vis TE 10x30	Schraube TE 10x30	12
17	0006626	Cuscinetto 6205-ZZ	Bearing 6205-ZZ	Roulement 6205-ZZ	Lager 6205-ZZ	3

# Rotomec: Cyclone 'C28'

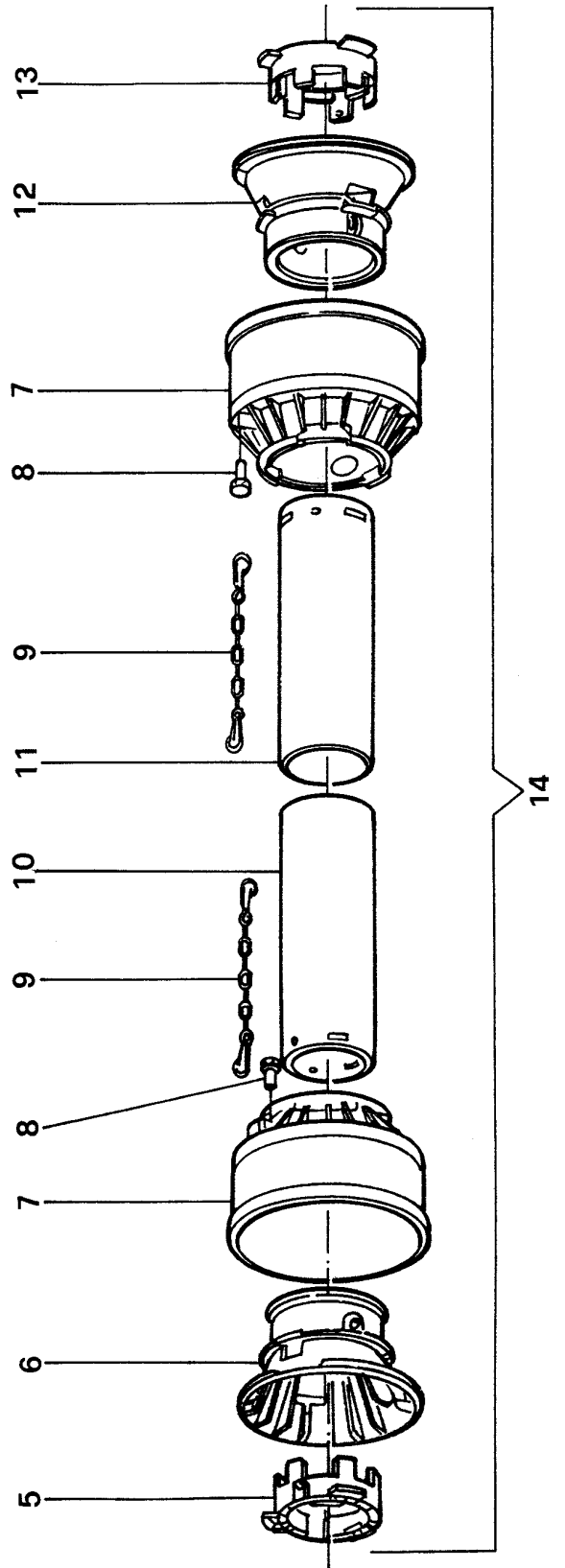
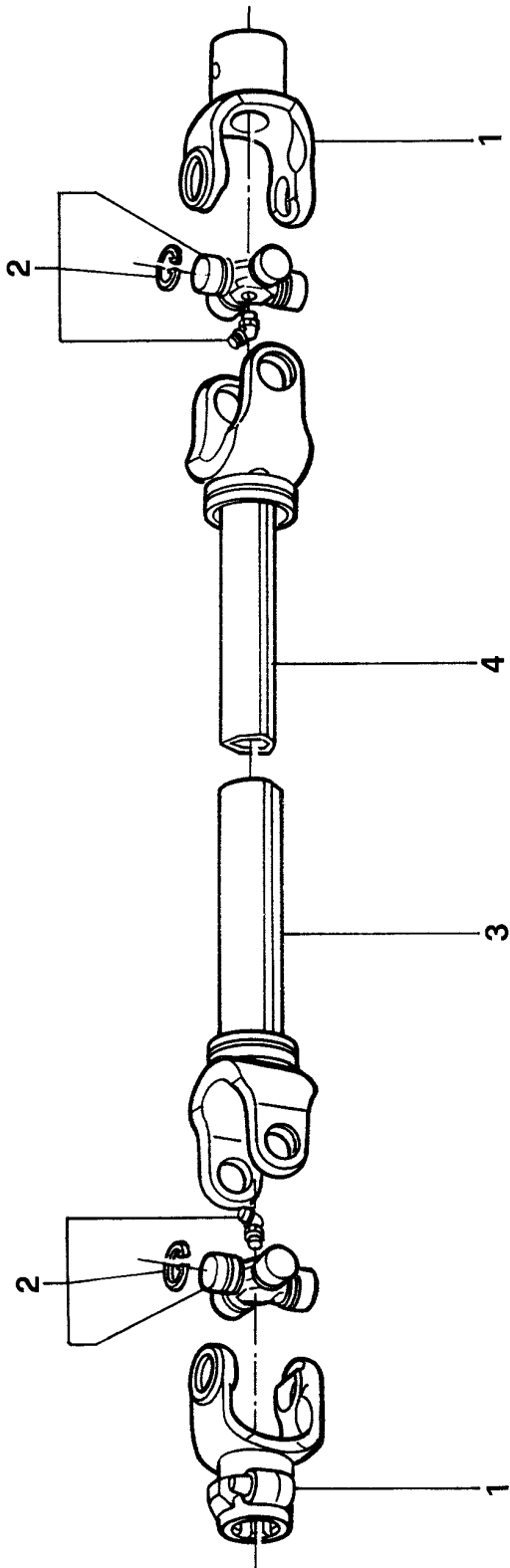



# Rotomec: Cyclone 'C28'

N.	COD.	DESCRIZIONE	DESCRIPTION	DESCRIPTION	BESCHREIBUNG	N.
1	022001E	Forcella P.D.F.	PTO Yoke	Fourche P.D.F.	Aufsteckgabel	2
2	012130E	Crociera	Cross & Bearing	Croisillon	Kreuzgelenk	2
3	1942045C	Tubo esterno v.120	Outer tube v.120	Tube externe v.120	Außenrohr v.120	1
	1942051C	Tubo esterno v.150	Outer tube v.150	Tube externe v.150	Außenrohr v.150	1
	1942066C	Tubo esterno v.180	Outer tube v.180	Tube externe v.180	Außenrohr v.180	1
4	1952047C	Tubo interno v.120	Inner tube v.120	Tube interne v.120	Innenrohr v.120	1
	1952053C	Tubo interno v.150	Inner tube v.150	Tube interne v.150	Innenrohr v.150	1
	1952068C	Tubo interno v.180	Inner tube v.180	Tube interne v.180	Innenrohr v.180	1
5	1782210C	Anello tubo esterno	Outer locking ring	Anneau tube externe	Außenrohrring	1
6	1784201C	Controcuffia tubo esterno	Outer tube rigid cone	Contre coiffe tube externe	Außenringgegentopf	1
7	1784203C	Cuffia esterna	Outer cone	Coiffe externe	Außenschutztopf	2
8	1784212C	Spina di bloccaggio	Pin	Goupille	Haltestift	2
9	016025E	Catenella	Chain	Chaîne	Kette	2
10	1773043C	Tubo protezione esterna v.120	Female tube shield v.120	Tube protection femelle v.120	Außenschutzrohr v.120	1
	1773049C	Tubo protezione esterna v.150	Female tube shield v.150	Tube protection femelle v.150	Außenschutzrohr v.150	1
	1773064C	Tubo protezione esterna v.180	Female tube shield v.180	Tube protection femelle v.180	Außenschutzrohr v.180	1
11	1872043C	Tubo protezione interna v.120	Male tube shield v.120	Tube protection mâle v.120	Innenschutzrohr v.120	1
	1872049C	Tubo protezione interna v.150	Male tube shield v.150	Tube protection mâle v.150	Innenschutzrohr v.150	1
	1872064C	Tubo protezione interna v.180	Male tube shield v.180	Tube protection mâle v.180	Innenschutzrohr v.180	1
12	1784202C	Controcuffia tubo interno	Inner tube rigid cone	Contre coiffe tube interne	Innengabelgegentopf	1
13	1782211C	Anello tubo interno	Inner locking ring	Anneau tube interne	Innenrohrring	1
14	9402443C	Protezione completa v.120	Complete shielding v.120	Protection complète v.120	Kompletter Schutz v.120	1
	90SS2049C	Protezione completa v.150	Complete shielding v.150	Protection complète v.150	Kompletter Schutz v.150	1
	9402464C	Protezione completa v.180	Complete shielding v.180	Protection complète v.180	Kompletter Schutz v.180	1
	0500434	Cardano v.120	PTO shaft v.120	Arbre à cardan v.120	Kardangelenk v.120	
	0500435	Cardano v.150	PTO shaft v.150	Arbre à cardan v.150	Kardangelenk v.150	
	0500436	Cardano v.180	PTO shaft v.180	Arbre à cardan v.180	Kardangelenk v.180	

# Rotomec: Cyclone 'C28' cat. 1N

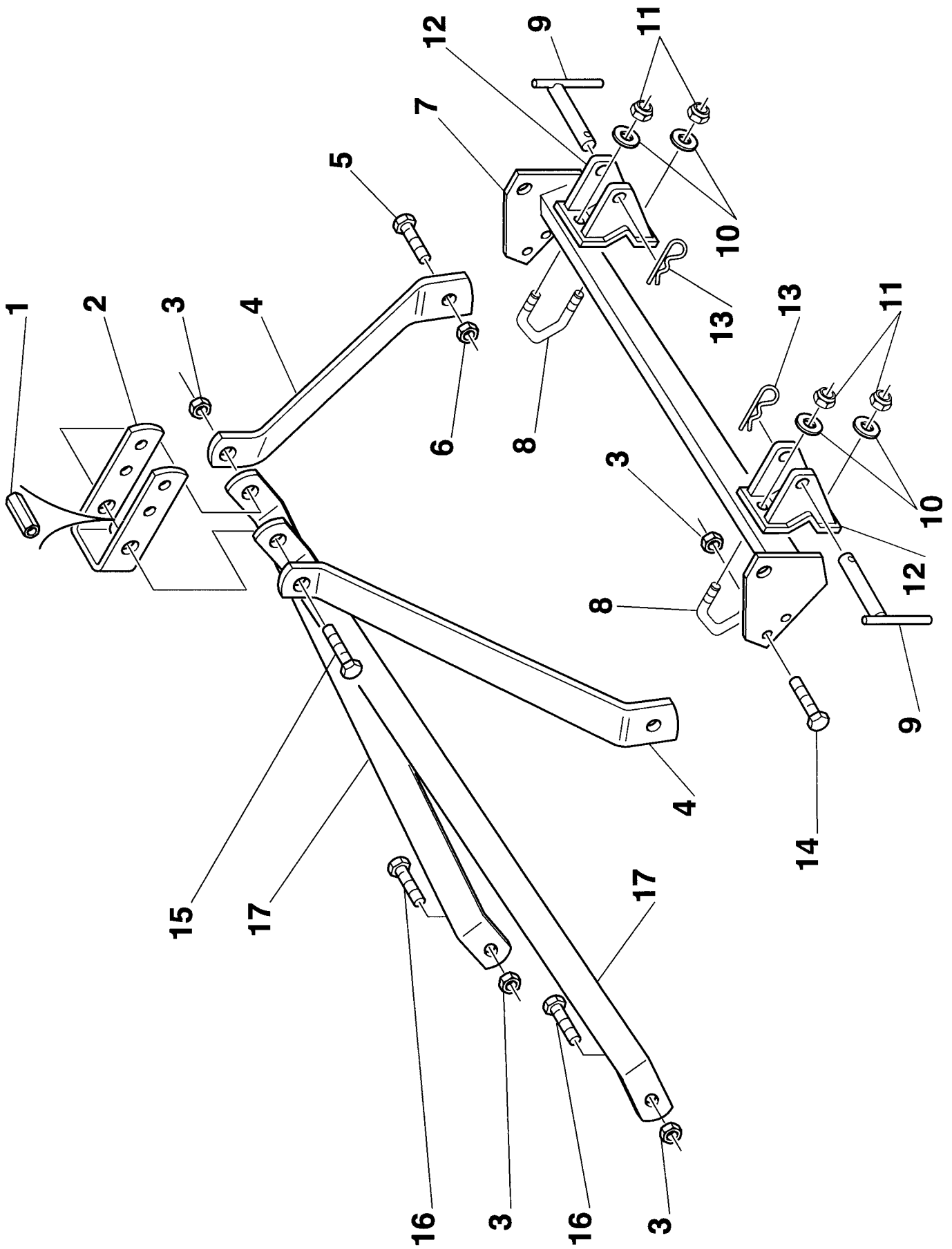

# Rotomec: Cyclone 'C28' cat. 1N

<b>N.</b>	<b>COD.</b>	<b>DESCRIZIONE</b>	<b>DESCRIPTION</b>	<b>DESCRIPTION</b>	<b>BESCHREIBUNG</b>	<b>N.</b>
1	0006829	Distanziale	Spacer	Entretoise	Distanzstück	1
2	0006828	Piastra superiore	Upper plate	Plaque supérieure	Obere Platte	1
3	0005581	Dado D.16	Nut D.16	Ecrou D.16	Mutter D.16	7
4	0051822	Lama verticale	Top hitch support	Lame verticale	Vertikale Strebe	2
5	0009538	Vite TE 20x45	Bolt TE 20x45	Vis TE 20x45	Schraube TE 20x45	2
6	0005507	Dado D.20	Nut D.20	Ecrou D.20	Mutter D.20	2
7	0051865	Supporto attacco trattore	Tractor hitch support	Support attelage tracteur	Schlepperanschlußsupport	1
8	0011251	Cavallotto	U Bolt	Barre d'ancrage	Bügelbolzen	2
9	0008501	Spina attacco trattore	Hitch pin	Axe attelage tracteur	Schlepperanschlußstift	2
10	0001077	Rosetta elastica D.12	Spring washer D.12	Rondelle élastique D.12	Sprengring D.12	4
11	0003038	Dado D.12	Nut D.12	Ecrou D.12	Mutter D.12	4
12	0006897	Piastra attacco trattore	Lower hitch arm	Support attelage tracteur	Schlepperanschlußplatte	2
13	0091507	Copiglia a molla D.4	Cotter pin D.4	Goupille ressort D.4	Federsplint D.4	2
14	0006578	Vite TE 16x45	Bolt TE 16x45	Vis TE 16x45	Schraube TE 16x45	4
15	0006891	Vite TE 16x140	Bolt TE 16x140	Vis TE 16x140	Schraube TE 16x140	1
16	0032687	Vite TE 16x40	Bolt TE 16x40	Vis TE 16x40	Schraube TE 16x40	2
17	0051824	Lama inclinata v.120	Top hitch arm v.120	Lame inclinée v.120	Geneigte Strebe v.120	2
	0051826	Lama inclinata v.150	Top hitch arm v.150	Lame inclinée v.150	Geneigte Strebe v.150	2
	0051828	Lama inclinata v.180	Top hitch arm v.180	Lame inclinée v.180	Geneigte Strebe v.180	2